



Top Page > Products/Technology > Product Search > Switches > Slide Switches > SSSU Series > SSSU012200 Product information

Register

Login

Switches Slide Switches

8.5 (H) mm, 3.0mm-travel Type SSSU Series

Part number **SSSU012200**

Standard ?

MEMBERS ONLY

Save Item

Basic information ▾	Dimensions ▾	Mounting Hole Dimensions ▾	Actuator Configuration ▾	Shape of Frame Leg ▾	Circuit Diagram ▾
Packing Specifications ▾	Soldering Conditions ▾				



NET SHOP

3D CAD

RoHS

Reference Drawings

Inquiry

Print

Travel	3.0mm	
Actuator directions	Vertical	
Actuator length	9.0mm	
Poles	1	
Positions	2	
Operating force	Refer to the dimensions.	
Mounting method	Snap-in (t1.6)	
Changeover timing	Non shorting	
Soldering	Manual, Dip	
Dimensions (W × D × H)	18.5 × 7.0 × 8.5mm	
Operating temperature range	-40°C to +85°C	
Rating (max.)/(min.) (Resistive load)	0.1A 30V DC/50 μA 3V DC	
Electrical performance	Contact resistance (Initial performance/After lifetime)	25mΩ max./65mΩ max.
	Insulation resistance	100MΩ min. 500V DC
	Voltage proof	500V AC for 1 minute
Mechanical performance	Terminal strength	5N for 1 minute
	Actuator strength	Operating direction
Pulling direction		30N
Durability	Operating life without load	10,000 cycles 45mΩ max.
	Operating life with load (at max. rated load)	10,000 cycles 65mΩ max.
Environmental performance	Cold	-40°C 500h
	Dry heat	85°C 500h
	Damp heat	60°C, 90 to 95%RH 500h
Minimum order unit(pcs.)	Japan	400
	Export	2,000

Dimensions

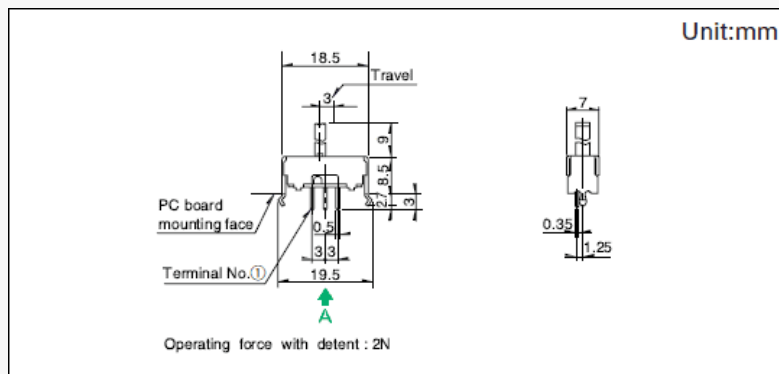

Mounting Hole Dimensions

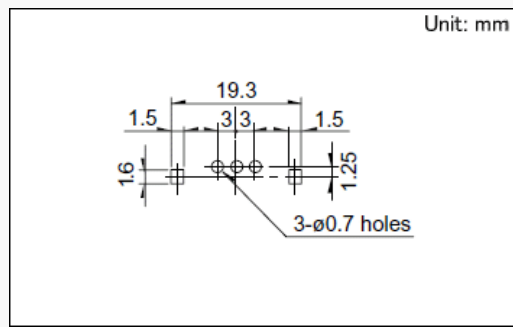

Viewed from direction A in the dimensions.

Actuator Configuration

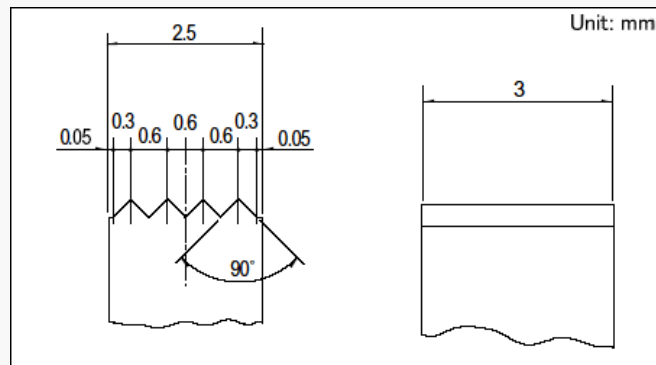

Shape of Frame Leg

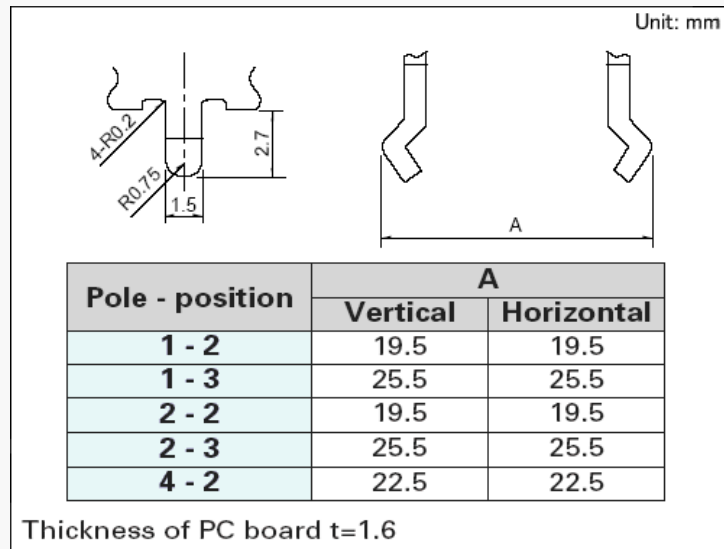

Circuit Diagram

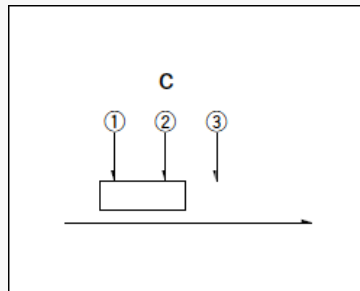

Packing Specifications

Bulk

Number of packages (pcs.)

1 case / Japan	400
1 case / export packing	2,000

Export package measurements (mm)

400 × 270 × 290

Soldering Conditions

Reference for Dip Soldering

Items

Preheating temperature	100°C max.
Preheating time	60s max.

Dip soldering

Soldering temperature	260±5°C
Duration of immersion	10±1s

Reference for Hand Soldering

Soldering temperature

350±10°C

Soldering time

3+1/0s

Notes are common to this series/models

1. This site catalog shows only outline specifications. When using the products, please obtain formal specifications for supply.
2. Please place purchase orders per minimum order unit (integer).
3. Products other than those listed in the above chart are also available. Please contact us for details.

Cautions

1. Applying load to terminals during soldering under certain conditions may cause deformation and electrical property degradation.
2. Avoid use of water-soluble soldering flux, since it may corrode the switches.
3. Check and conform to soldering requirements under actual mass production conditions.
4. When soldering twice, wait until the first soldered portion cools to normal temperature. Continuous heating will deform the external portions, loosen or dislodge terminals, or may deteriorate their electrical characteristics.
5. Flux from around and above the PC board should not adhere to the switches.
6. After mounting the switches, if you intend to put the board into an oven in order to harden adhesive for other parts, please consult with us.
7. If you use a through-hole PC board or a PC board thinner or thicker than the recommendation, there may be greater heat stress. Verify the soldering conditions thoroughly before use.
8. Solder the switches with detent at the detent position. Soldering switches fixed at the center of the detent may deform the detent mechanisms.
9. No cleaning.
10. Protect small and thin switches from external forces in the set mounting process.
11. Tighten the mounting screws by applying the specified torque. Tightening with larger torque than the specified one will result in malfunction or breakage of screws.
12. Insert these switches to the specified mounting surface and mount them horizontally. If not mounted horizontally, these switches will malfunction.
13. The products are designed and manufactured for direct current resistance. Contact us for use of other resistances such as inductive (L) or capacitive (C).
14. The switch will break if you apply a greater stress than that specified. Take great care not to let the switch be subject to greater stress than specified.
15. Use of the switches in a dusty environment may lead to dusts entering through the openings and cause imperfect contact or malfunction. Take this into account for set design.
16. Corrosive gas if generated by peripheral parts of a set, malfunction such as imperfect contact may occur. Thorough investigation shall be required beforehand.
17. Storage
Store the products as delivered at normal temperature and humidity, out of direct sunlight and away from corrosive gases. Use them as soon as possible and no later than six months after delivery.
Once the seal is broken, use them as soon as possible.

Measurement and Test Methods

Rotational Torque (Operating Force)

Measures the torque (operating force) necessary to rotate (move) the shaft (lever). Unless otherwise specified, measurement shall be made at ambient temperatures of 5 to 35° C, the shaft rotational speed shall be 60° per second, and the lever traveling speed shall be 20mm per second.

Shaft Wobble

Measures the amount of deflection at the specified position from the reference plane, with the specified bending moment, applied perpendicularly to the shaft from directions 180 degrees with respect to each other.

Withstand Voltage

Applies AC voltage to the specified spot for a minute and then checks for arc, burning, dielectric breakdown and other abnormalities. Respective terminals may be tested as a group. The sections described below shall be tested unless otherwise specified. However, if the section concerned is so constructed as to conduct, that particular part shall not be tested.

Insulation Resistance

Applies specified voltage to the specified locations and then measures the insulation resistance with a megger. The locations described below shall be tested unless otherwise specified. However, if the section concerned is so constructed as to conduct, that particular part shall not be tested.

Sections to be Tested for Withstand Voltage and Insulation Resistance

- Between terminal and shaft (lever).
- Between terminal and metal cover (frame).

Shaft (Lever) Strength against Push/Pull Actions

Applies a specified force in the axial direction of the shaft (lever) for 19 seconds and then checks the operating part and other sections for deformation, breakage, operating conditions, etc.